

Revisions:

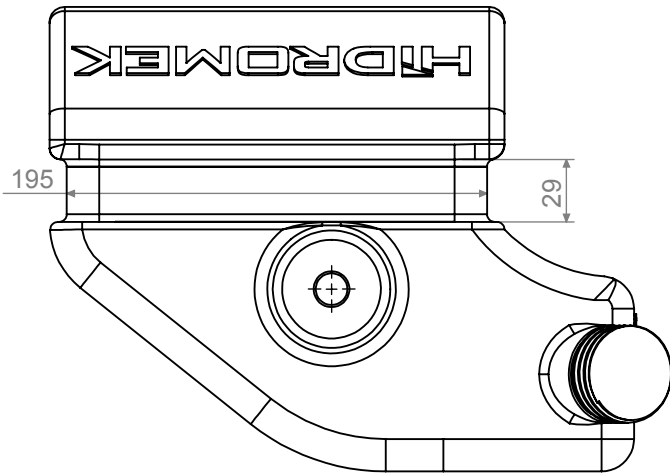

| GENEL TOLERANS TABLOSU DIN 2768 |            |        |         |           |            |             |              |              |    |
|---------------------------------|------------|--------|---------|-----------|------------|-------------|--------------|--------------|----|
| TOLERANS SINIFI                 | 0,5<br>3   | 3<br>6 | 6<br>30 | 30<br>120 | 120<br>400 | 400<br>1000 | 1000<br>2000 | 2000<br>4000 |    |
| f                               | Çok Hassas | ±0,05  | ±0,05   | ±0,1      | ±0,15      | ±0,2        | ±0,3         | ±0,5         | -  |
| m                               | Hassas     | ±0,1   | ±0,1    | ±0,2      | ±0,3       | ±0,5        | ±0,8         | ±1,2         | ±2 |
| c                               | Kaba       | ±0,2   | ±0,3    | ±0,5      | ±0,8       | ±1,2        | ±2           | ±3           | ±4 |
| v                               | Çok Kaba   | -      | ±0,5    | ±1        | ±1,5       | ±2,5        | ±4           | ±6           | ±8 |

| No | Part Definition | AFK S.C.              | Material       | Quantity  |
|----|-----------------|-----------------------|----------------|-----------|
|    |                 |                       |                |           |
|    |                 | Date                  | Name-Surname   | Signature |
|    | Drawn by        | 27.09.2011            | Arzu ÇAVDAR    |           |
|    | Approved by     | 27.09.2011            | Afşin KANDEMİR |           |
|    | Scale           | Part definition       |                |           |
|    | 1:3,5           | GENLEŞME TANKI        |                |           |
|    |                 | Drawing               | 115AC037 R0    |           |
|    |                 | Material              | PP             |           |
|    |                 | Non -defined Tolerans | (c) Kaba       |           |

**AFK** Otomotiv  
Elektromekanik, Plastik  
İmalat San. Tic. Ltd. Sti.